

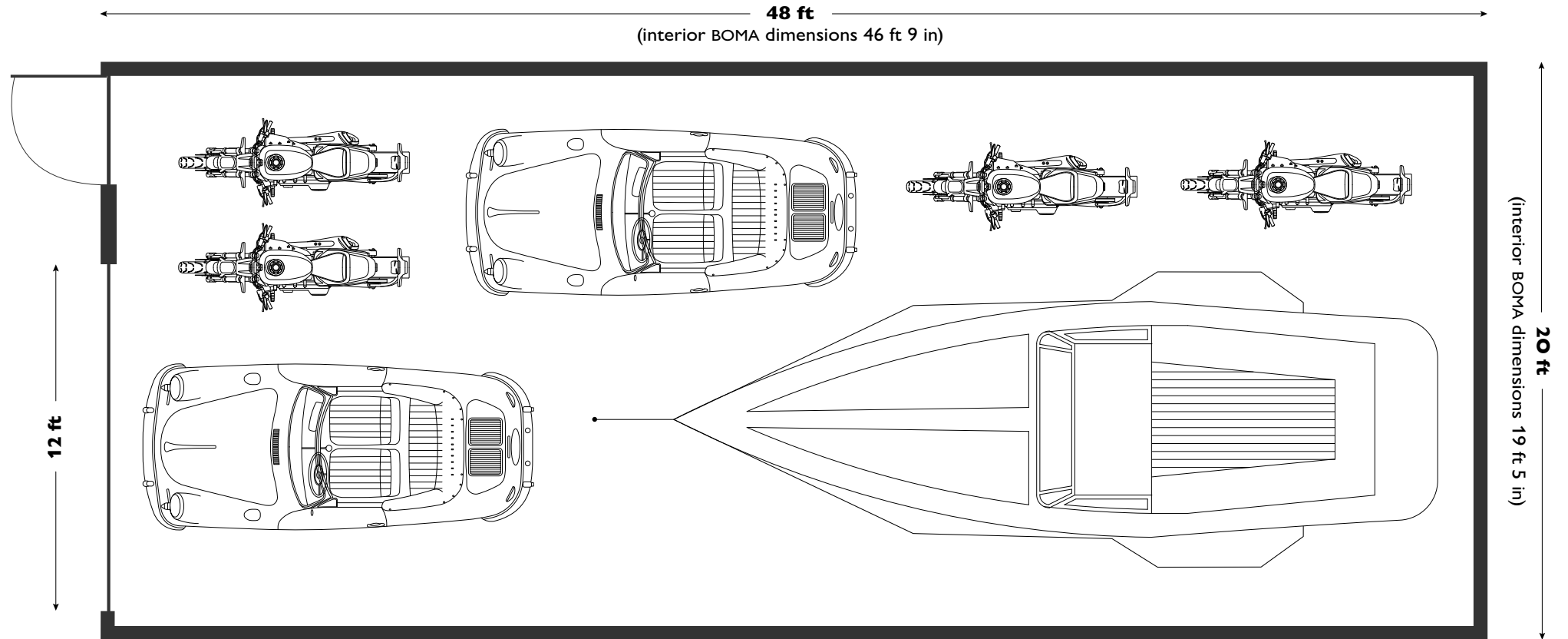

NAPA VAULT

20'x48' Floor Plan



707.343.4389



NAPAVULT.COM



sales@napavault.com



1055 SOSCOL FERRY RD / NAPA, CA 94558



This 20' x 48' floor plan yields interior BOMA dimensions of 19' 5" x 46' 9". Rendering is for illustration purposes only. Buyers are responsible for measuring vehicles and other collectibles to ensure proper storage capacity. The vehicles depicted in this rendering include: Chris-Craft Boat with Trailer (approx. 30'L x 11'W), Porsche 356C (approx. 13.5'L x 6'W) and Harley-Davidson Softail FXDR (approx. 8'L). All vehicle measurements are approximate. A minimum of approximately 1.5' to 2' of space has been left between vehicles and walls. This condominium can yield greater car capacity when lifts are added.

Jones Lang LaSalle Brokerage, Inc. Real Estate License #: 01856260 ©2021 Jones Lang LaSalle IP, Inc. All rights reserved. All information contained herein is from sources deemed reliable; however, no representation or warranty is made to the accuracy thereof.